



# LINEA 35

## PUERTAS DE ALUMINIO

---

- ✓ Esta línea corresponde a las Puertas de aluminio, que por lo general son usadas para oficinas o viviendas. Posee dos tipos de aperturas. La primera es la abatible, la cual genera la posibilidad de aperturas hacia el interior o el exterior. En tanto, la apertura de vaivén contiene el accesorio quicio hidráulico, el cual permite ser abierta en ambas direcciones.
- ✓ Esta línea contiene accesorios de bisagras (plana y embutidas) cerraduras, quicios mecánicos e hidráulicos y picaportes.

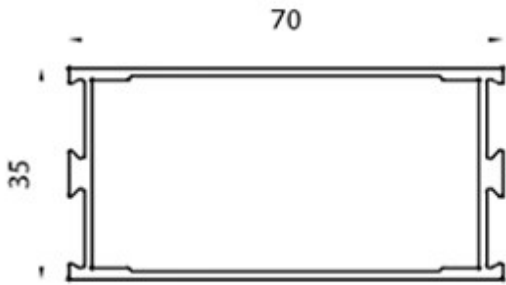

3501  
Bastidor

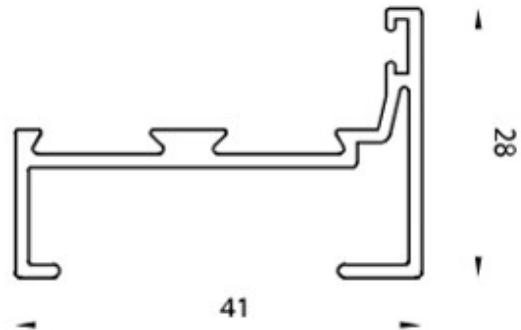

3502  
Marco

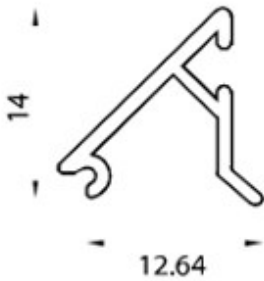

3503  
Junquillo 45°

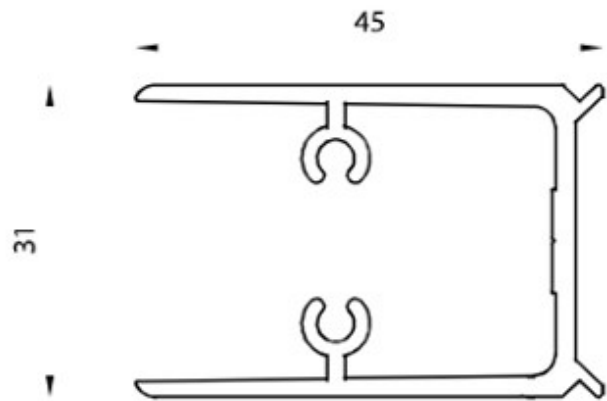

3511  
Escuadra de armado NAT.

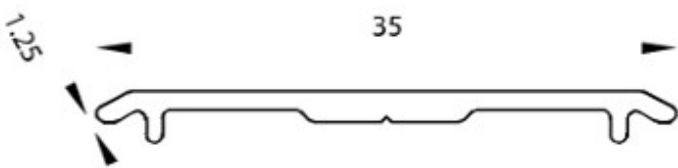

3506  
Tapa Ciega

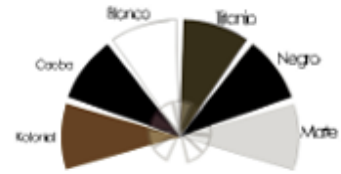

Colores disponibles

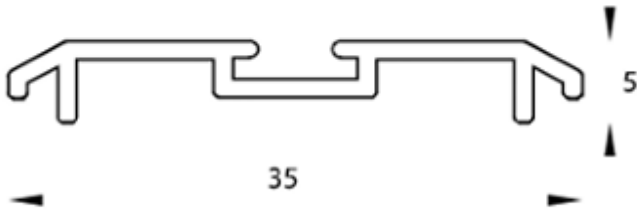

3507  
Tapa portafelpa

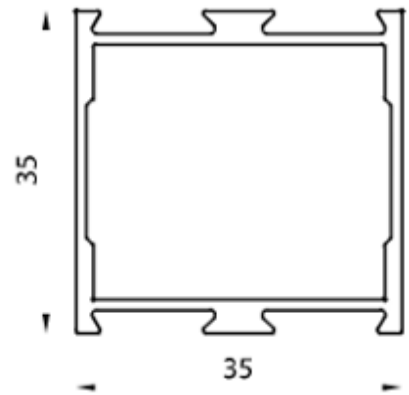

3508  
Bastidor Chico

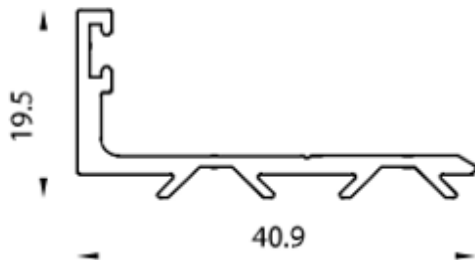

3509  
Traslapo puerta



## QUINCALLERIA



CERRADURA ITO 25mm



CERRADURA ITO 35mm

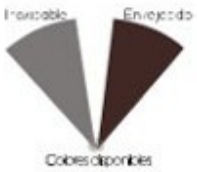

CERRADURA SCANAVINI 1270 AC. INOX



CERRADURA SCANAVINI 1070 ENVEJECIDA

## QUINCALLERIA



CERRADURA SCANAVINI 1080 AC.  
INOX M.960 L



CERRADURA ITO 35 MM (1080)



CERROJO MARIPOSA INTERIOR AC.  
INOX SCANAVINI



CERRADURA SCANAVINI 1280 AC.  
INOX M.960 L

### QUINCALLERIA



TIRADOR PUERTA AC. INOX TIP 301B  
22 X 300 SCANA



TIRADOR PUERTA AC. INOX TIP 205  
32 X 600 SCANA



TOPE PUERTA AC. INOX TOP 001  
SCANAVINI



QUICIO HIDRAULICO SCANAVINI  
DT-2300 90



QUICIO MECANICO SIN PLACA 615 SCANAVINI



CIERRA PTA. AEREO DT- 63H SCANAV

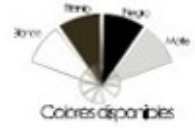

BISAGRA AM-35 NEGRA



PESTILLO CUCHARA